

# **O-NOZZLE** **by SPRATRONICS®**

## **Installation Manual**



### **Solid Stream O-NOZZLE**

This new, more efficient **O-NOZZLE** design permits several different tips to be attached to the nozzle body. This manual shows how to use the solid stream tip for anti-icing and de-icing. Contact factory for information on how to use deflector tips for anti-icing or prewetting.

This variable orifice nozzle is used for reaching outside lanes either side of the center lane. It will produce a cohesive solid stream through air turbulence even at high speeds. It is also used for the center lane with the 4 spray streams crossing behind the truck to fully spread liquid mixtures across the lane. Alternately, deflector tips may be used for the center lane but not outside lanes.

### **Spratronics Contact Information**

**20403 80<sup>th</sup> Ave SE**

**Snohomish, WA 98296**

**Tel: 360-668-2548**

**Toll Free: 866-668-3444**

**Fax: 360-668-3784**

**[www.spratronics.com](http://www.spratronics.com)**

# Center Lane **○-NOZZLE** Assembly

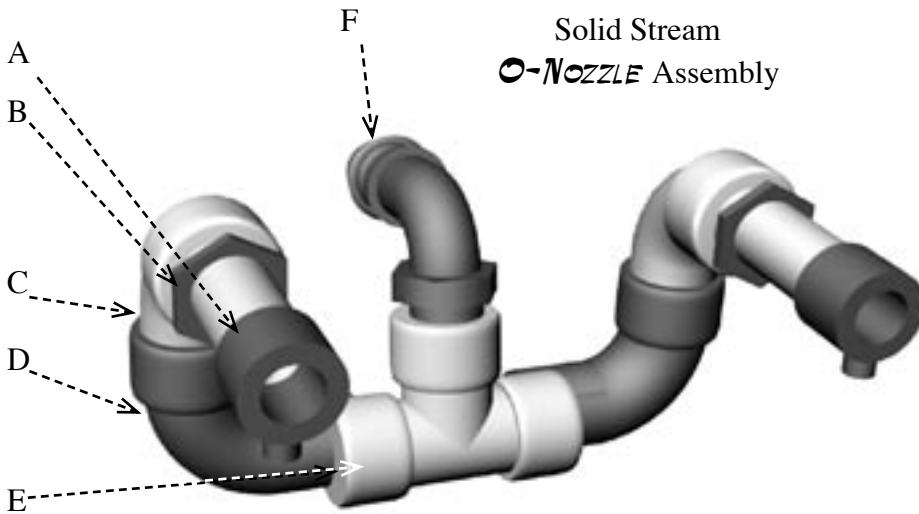

Solid Stream  
**○-NOZZLE** Assembly

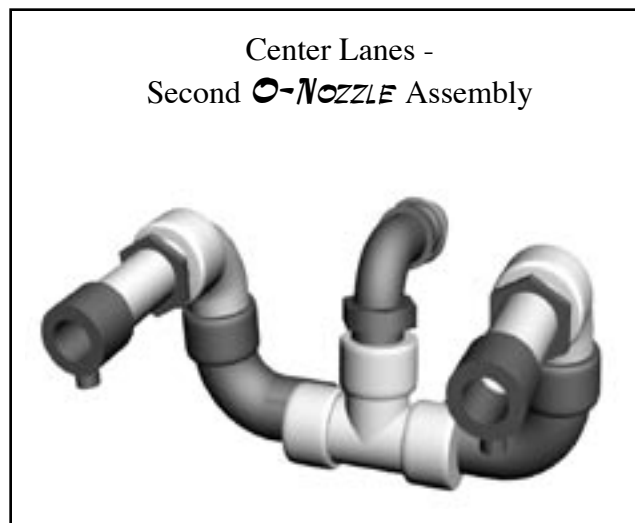

Center Lanes -  
Second **○-NOZZLE** Assembly

## Bill of Materials

1 – Two **○-NOZZLE** Assembly

Code	Qty	Description	Size	Material
A	2	Solid Stream <b>○-NOZZLE</b> , Model VO265	13GPM, 1/2" NPT	
B	2	Reducer bushing – female/male	1" x 1/2" NPT	GFP*
C&D	4	Street elbow – female/male	1" NPT	GFP*
E	1	Tee – female	1" NPT	GFP*
F	1	Street Elbow with male hose barb	1" NPT	GFP*

\*GFP - Glass Filled Polypropolene (Banjo or equivalent)

The drawings on this page shows 1- two **○-NOZZLE** assembly. In use, this will cover one half of the center lane. Two of these must be built to spray the full width of the center lane.

## Assembly Instructions:

1. Organize all items per bill of materials
2. Wrap all male threaded parts with 5-7 turns of Teflon tape.
3. Starting with tee ( Part **E** of drawing) install each street el (**D**) followed by second street el (**C**) and tighten moderately by hand.
4. Install reducer bushing (**B**) and tighten.
5. Attach **○-NOZZLES** (**A**) and moderately hand tighten. *Note: Do not grip nozzle endcap when installing nozzles. Calibration may be lost.*
6. *Caution – to properly aim **○-NOZZLES** (see page 8), they must be able to rotate in the horizontal plane. They must also be free to turn vertically at the joint between the street els and the tee. Tighten firmly enough to hold positions when in service but loosely enough to be aimed by hand adjustments.*
7. Install street elbow with hose barb (**F**).

# Side Lanes **O-NOZZLE** Assembly

The large drawing on this page shows 1-four **O-NOZZLE** assembly. In use, this will cover one entire lane on either side of the center lane. Two of these must be built to spray both the right-hand lane as well as the left-hand lane.

## Assembly Instructions

1. Organize all items per bill of material.
2. Wrap all male threaded parts with 5-7 turns of Teflon tape.
3. Build 2- two **O-NOZZLE** assemblies following steps 3-5 on page 4 using Solid Stream **O-NOZZLES**.
4. Using large 1 1/4" tee (G), install both reducers as shown in drawing.
5. Attach the two **O-NOZZLE** assemblies to the reducers and moderately tighten.
6. *Caution – to properly aim **O-NOZZLES** (see page 8), they must be able to rotate in the horizontal plane. They must also be free to turn virtually at the joint between the street els and the tee. Tighten firmly enough to hold positions when in service but loosely enough to be aimed by hand adjustments. Never grip nozzle end cap to install, adjust or aim nozzle*
7. Install the street el with hose barb(I) and tighten.

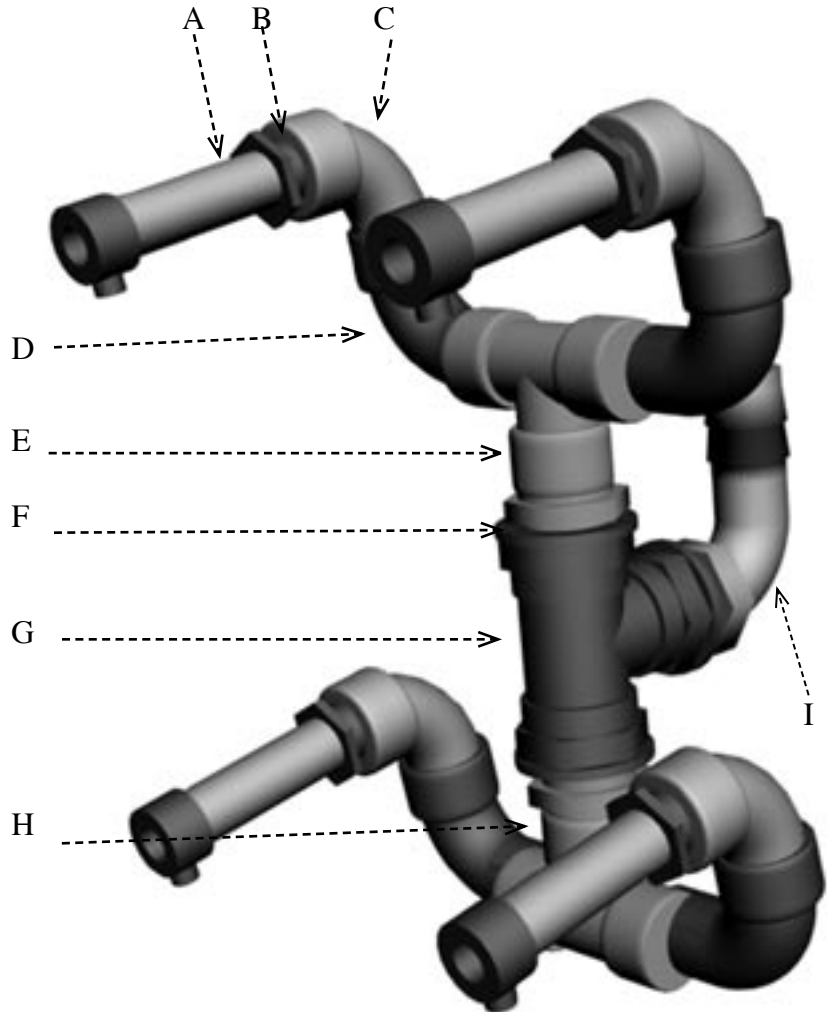

## Bill of Materials

1 – Four **O-NOZZLE** Assembly

Code	Qty	Description	Size	Material
A	4	Straight Stream <b>O-NOZZLE</b> , Model VO265	13GPM, 1/2" NPT	
B	4	Reducer bushing – female/male	1" x 1/2" NPT	GFP*
C&D	8	Street elbow – female/male	1" NPT	GFP*
E	1	Tee – female	1" NPT	GFP*
F	2	Reducer nipple – male	1 1/4" x 1" NPT	GFP*
G	1	Tee – female	1 1/4" NPT	GFP*
H	1	Tee – female	1" NPT	GFP*
I	1	Street elbow male w/hose barb	1 1/4" NPT	GFP*

\*GFP – Glass Filled Polypropolene (Banjo or Equivalent)

# Mounting Bracket Assembly

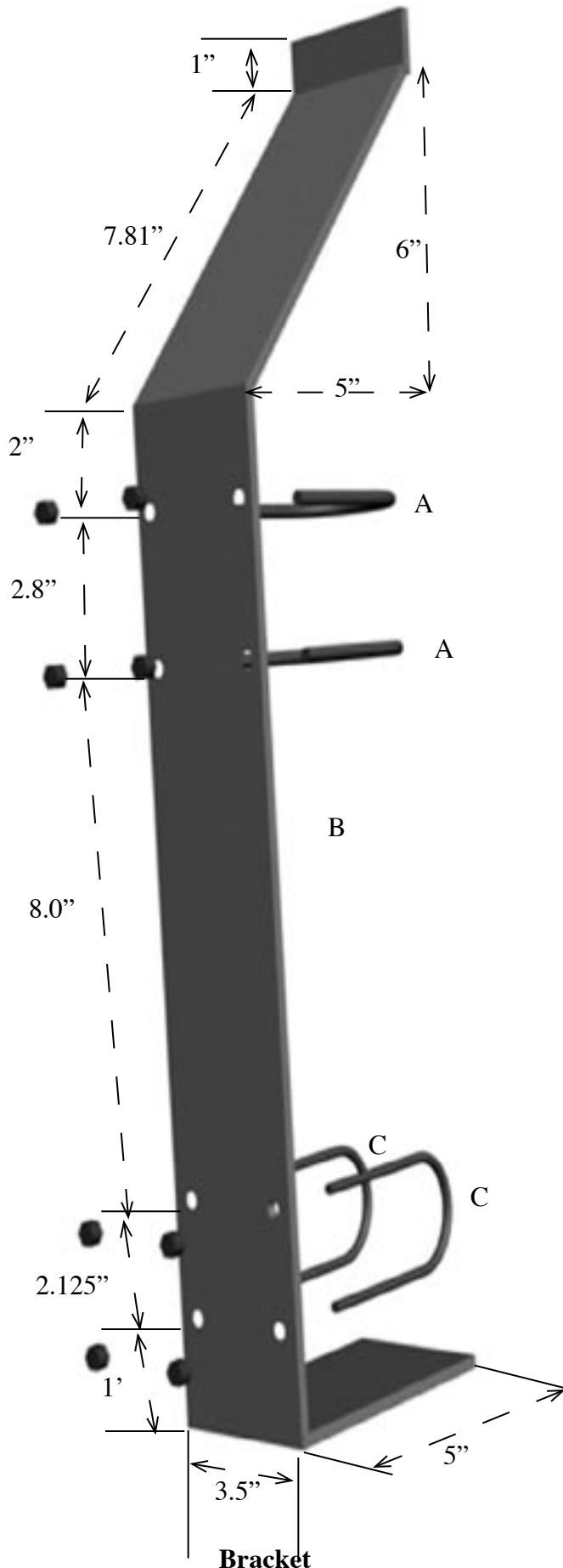

The mounting bracket has been designed to accomplish several goals:

1. To position the **O-NOZZLES** conveniently and effectively to achieve their best spray patterns.
2. To provide a strong and rugged base for the assemblies.
3. To help protect the **O-NOZZLE** assemblies against accidental damage.
4. To provide an inexpensive and easy-to-manufacture mounting system.
5. To eliminate the cost and complexities of spray boom assemblies.

## Assembly Instructions

1. Using 1/4" steel, mark dimensions as shown prior to bending.
2. Build jig per shop practices for hole punching or drilling as shown in cutaway drawing.
3. Punch or drill holes.
4. Using press brake, bend as shown.
5. Save the U bolts for attaching the **O-NOZZLE** assemblies.

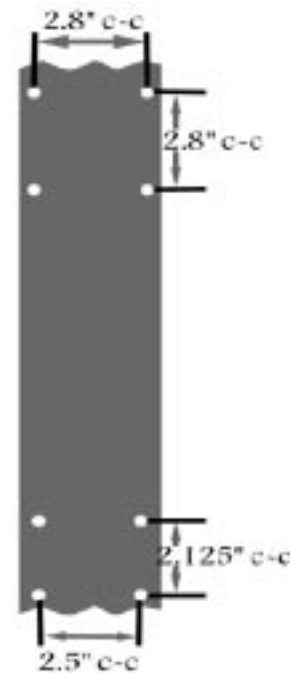

Cutaway Drawing

## Bill of Materials

1 Mounting Bracket Assembly

Code	Quantity	Description	Size
A	2	U-Bolts w/nuts	5/16" x 2" x 3 1/4"
B	1	Steel	1/4" x 3.5" x 29.735"
C	2	U-Bolts w/nuts	5/16" x 1 3/4" x 3"

# Installing Completed Nozzle System

The vertical mounting bracket usually is ideally suited to be welded to a flat vertical member on the skid. To accommodate requirements that the **O-NOZZLE** assemblies be vertically adjustable in relation to their height, we recommend that two lengths of square tubing be employed, one sliding inside of the other. With the use of bolts and predrilled holes, the tube carrying the **O-NOZZLE** assemblies can then be raised or lowered. For spraying, lower bottom **O-NOZZLE** to 20" or so above the roadway, being sure this does not cause assembly to strike hidden obstacles during operations. Keeping spray streams low minimizes disruptions to other drivers.

The two mounting brackets should be attached to the vertical legs of the skid at the rear outside corners. The brackets should be placed so the outside edges of the **O-NOZZLES** themselves are approximately 8' apart and within the outside edges of truck. If your sprayers have self-unloading legs, attach brackets to the legs.

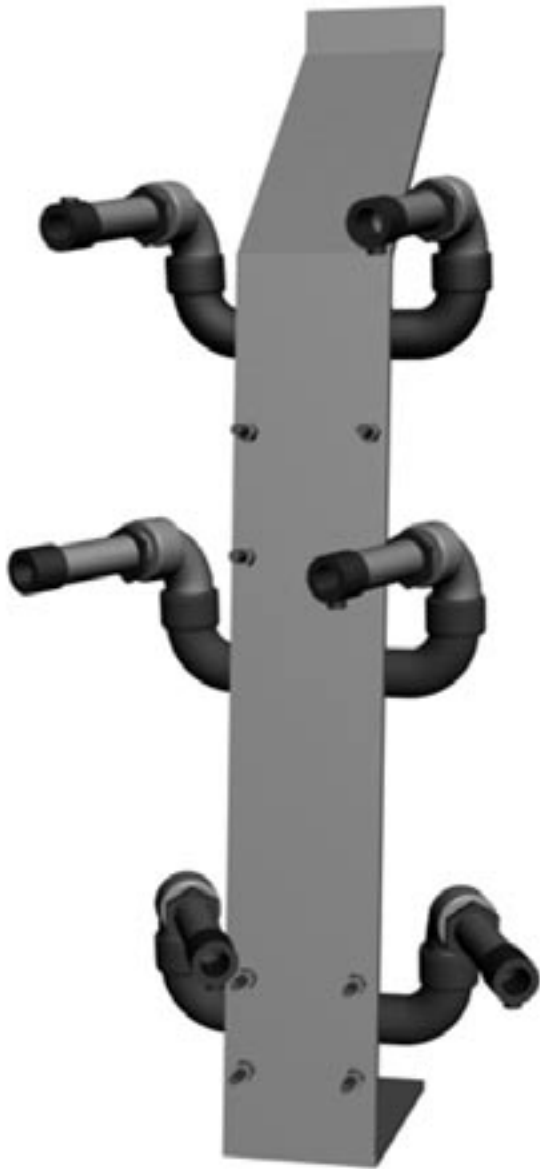

## Installing the **O-NOZZLE** Assemblies

Once the brackets are welded in place, the nozzle assemblies can be attached with the U-bolts holding them firmly in place as shown in the drawings. Hoses can then be routed to the hose barbs and hose clamps tightened.

*Do not grasp **O-NOZZLE** tips to aim.*

Close-up of U Bolts

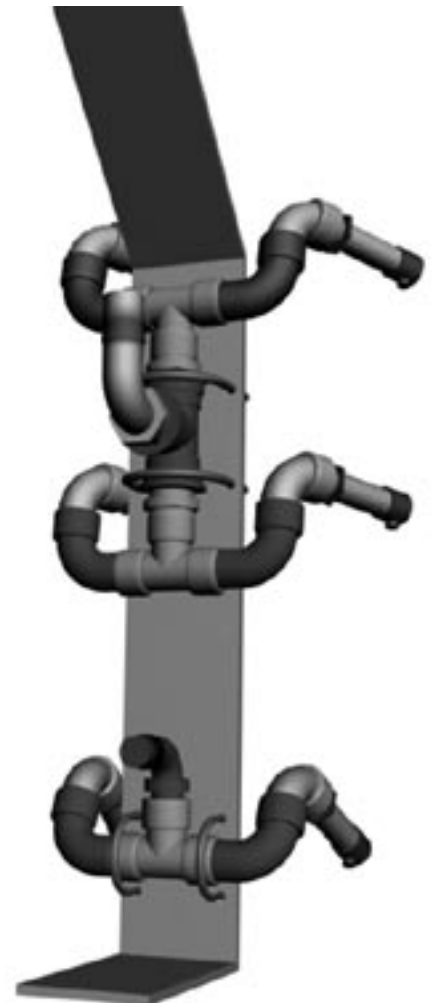

# How to Set Up Correct Spray Patterns

## Mark the Measurement per Drawings

1. Paint targets on shop parking lot.
2. Alternately- paint targets on white plastic pipes.  
Weight pipes so they will not move when sprayed.
3. Park truck in front of marks as shown.

## Nozzle Maintenance

There is no field maintenance required of **O-NOZZLES**. In case of breakage or damage due to an accident, contact the factory for replacements.

*Caution: All O-NOZZLES are factory calibrated and flow rates cannot be reset in the field.*

Anytime nozzle aiming is inadvertently changed, set up the target dimensions as shown and re-aim.

Ask vehicle operators to watch for any misalignment.

## System Maintenance

Do not allow any liquid remaining in the system to freeze.

## Annual Maintenance

Prior to beginning each season, it is a good idea to recheck nozzle aiming to insure correct spray patterns. This is especially true if the tank has been removed or if truck unit has been converted to an alternative seasonal usage.

## Test and Aim

1. Set ground speed controller on override mode at 30 gpm.
2. Set simulated ground speed at 30mph.
3. While spraying, aim each nozzle to hit its designated target.
4. For the Center Lane:  
**If solid stream nozzles**, criss-cross spray streams as shown and vertically offset streams so they do not collide. **If deflector nozzles**, do not criss-cross. Aim at tire tracks and reduce target distance to 6' behind truck.

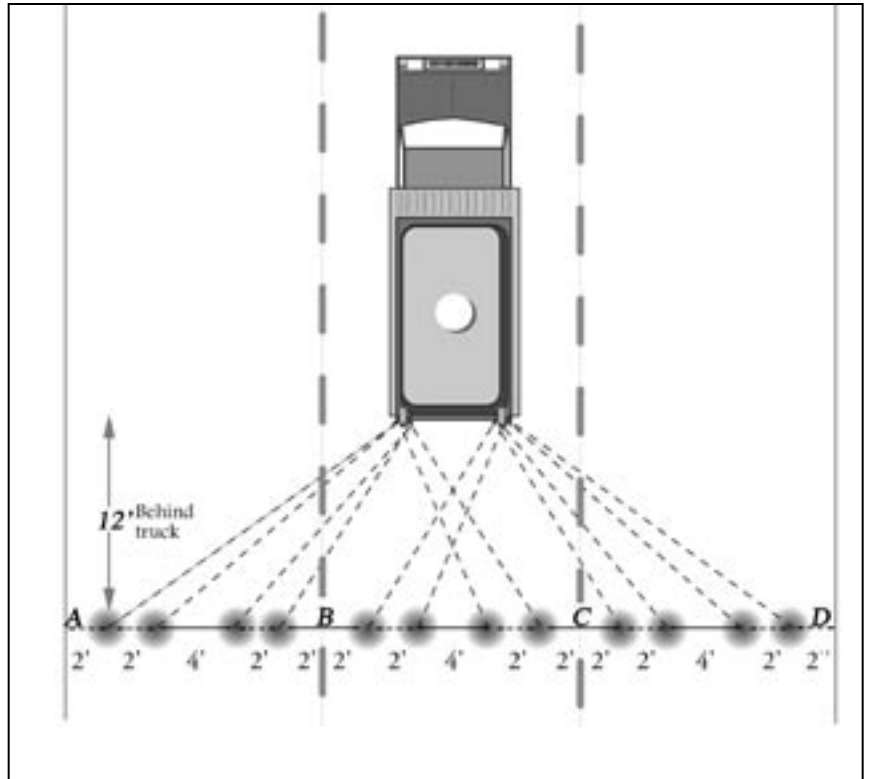

C/L Nozzle Spray Distances

Lane Widths	A From Outside Edge	B Between Lanes	C Between Lanes	D From Inside Edge
12'	2'	4'	4'	2'
11'	1.5'	3'	3'	1.5'

**Warning - when highway spraying, be certain ground speed override is always off.**

20403 80<sup>th</sup> Ave SE  
Tel: 360-668-2548  
Fax: 360-668-3784



Snohomish, WA 98296  
Toll Free 1-866-668-3444  
www.spratronics.com